

Series HDD 30

DN15 PN315

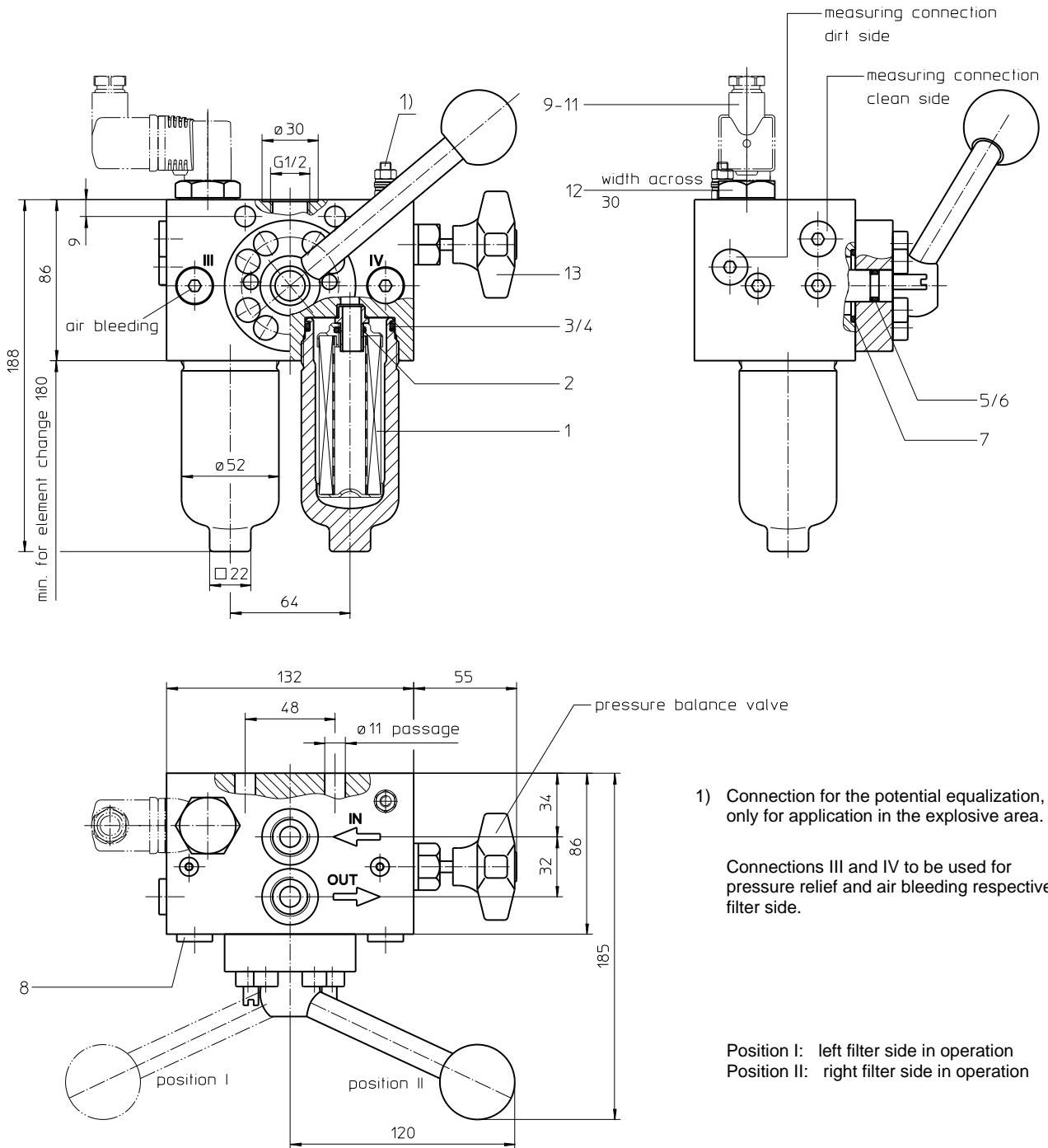

Weight: approx. 8 kg

Dimensions: mm

Designs and performance values are subject to change.



Powering Business Worldwide

Pressure Filter, change over Series HDD 30 DN15 PN315

Description:

Pressure filters change over series HDD 30 are suitable for operating pressure up to 315 bar. The pressure peaks are absorbed by a sufficient margin of safety.

Duplex filters can be serviced without interruption of operation. The upper part has a three-way-change-over valve which allows to change-over the flow from the dirty filter-side to the clean filter-side without interrupting the operation. The change-over procedure does not lead to a cross sectional contraction. Prior to the change-over procedure a built-in pressure balance valve equalizes the housing pressure. After change-over the pressure balance valve is to be closed again. The closed filter-side has to be air-bled by vent III respectively by vent IV. Then change filter element. After screw in the filter bowl the pressure balance has to be opened shortly and the just serviced filter-side has to be air-bled. Filter elements are available down to a filter fineness of $5 \mu\text{m}_{(C)}$.

Eaton filter elements are known for high intrinsic stability and an excellent filtration capability, a high dirt-retaining capacity and a long service life.

Eaton filter elements are available with a pressure difference resistance up to Δp 160 bar and a rupture strength up to Δp 250 bar.

The internal valves are integrated into the centering pivot for the filter element. After reaching the opening pressure the by-pass valve causes that an unfiltered partial flow passes the filter.

Eaton filter are suitable for all petroleum based fluids, HW-emulsions, most synthetic hydraulic fluids and lubrication oils.

Type index:

Complete filter: (ordering example)

HDD.	30.	10VG.	HR.	E.	P.	-.	G.	3.	-.	-.	AE
1	2	3	4	5	6	7	8	9	10	11	12

- 1 series:**
HDD = pressure filter change over
- 2 nominal size:** 30
- 3 filter material:**
25VG, 16VG, 10VG, 6VG, 3VG microglass
- 4 filter element collapse rating:**
30 = Δp 30 bar
HR = Δp 160 bar (rupture strength Δp 250 bar)
- 5 filter element design:**
E = single-end open
- 6 sealing material:**
P = Nitrile (NBR)
V = Viton (FPM)
- 7 filter element specification:**
- = standard
VA = stainless steel
IS06 = for HFC application, see sheet-no. 31601
- 8 process connection:**
G = thread connection according to ISO 228
- 9 process connection size:**
3 = G $\frac{1}{2}$
- 10 filter housing specification:**
- = standard
- 11 internal valve:**
- = without
S1 = with bypass valve Δp 3,5 bar
S2 = with bypass valve Δp 7,0 bar
- 12 clogging indicator or clogging sensor:**
- = without
AOR = visual, see sheet-no. 1606
AOC = visual, see sheet-no. 1606
AE = visual-electric, see sheet-no. 1615
VS5 = electronic, see sheet-no. 1619

To add an indicator/sensor to your filter, use the corresponding indicator data sheet to find the indicator details and add them to the filter assembly model code.

Filter element: (ordering example)

01E.	30.	10VG.	HR.	E.	P.	-
1	2	3	4	5	6	7

- 1 series:**
01E = filter element according to company standard
- 2 nominal size:** 30
- 3 - 7** | see type index-complete filter

Accessories:

- gauge port- and bleeder connections, see sheet-no. 1650

Technical data:

operating temperature:	-10 °C to +100 °C
operating medium:	mineral oil, other media on request
max. operating pressure:	315 bar
test pressure:	450 bar
standard process connection:	thread connection according to ISO 228
housing material:	EN-GJS-400-18-LT, carbon steel
sealing material:	Nitrile (NBR) or Viton (FPM), other materials on request
installation position:	vertical
measuring- and bleeder connections:	G ¼
volume tank:	2x 0,11 l

Classified under the Pressure Equipment Directive 2014/68/EU for mineral oil (fluid group 2), Article 4, Para. 3.
 Classified under ATEX Directive 2014/34/EU according to specific application (see questionnaire sheet-no. 34279-4).

Pressure drop flow curves:

Filter calculation/sizing

The pressure drop of the assembly at a given flow rate Q is the sum of the housing Δp and the element Δp and is calculated as follows:

$$\Delta p_{assembly} = \Delta p_{housing} + \Delta p_{element}$$

$$\Delta p_{housing} = (\text{see } \Delta p = f(Q) - \text{characteristics})$$

$$\Delta p_{element} (mbar) = Q \left(\frac{l}{min} \right) \times \frac{MSK}{10} \left(\frac{mbar}{l/min} \right) \times v \left(\frac{mm^2}{s} \right) \times \frac{p}{0,876} \left(\frac{kg}{dm^3} \right)$$

For ease of calculation our Filter Selection tool is available online at www.eaton.com/hydraulic-filter-evaluation

Material gradient coefficients (MSK) for filter elements

The material gradient coefficients in mbar/(l/min) apply to mineral oil (HLP) with a density of 0,876 kg/dm³ and a kinematic viscosity of 30 mm²/s (139 SUS). The pressure drop changes proportionally to the change in kinematic viscosity and density.

HDD	VG				
	3VG	6VG	10VG	16VG	25VG
30	10,116	7,023	4,496	3,915	2,674

$\Delta p = f(Q)$ – characteristics according to ISO 3968

The pressure drop characteristics apply to mineral oil (HLP) with a density of 0,876 kg/dm³. The pressure drop changes proportionally to the density.

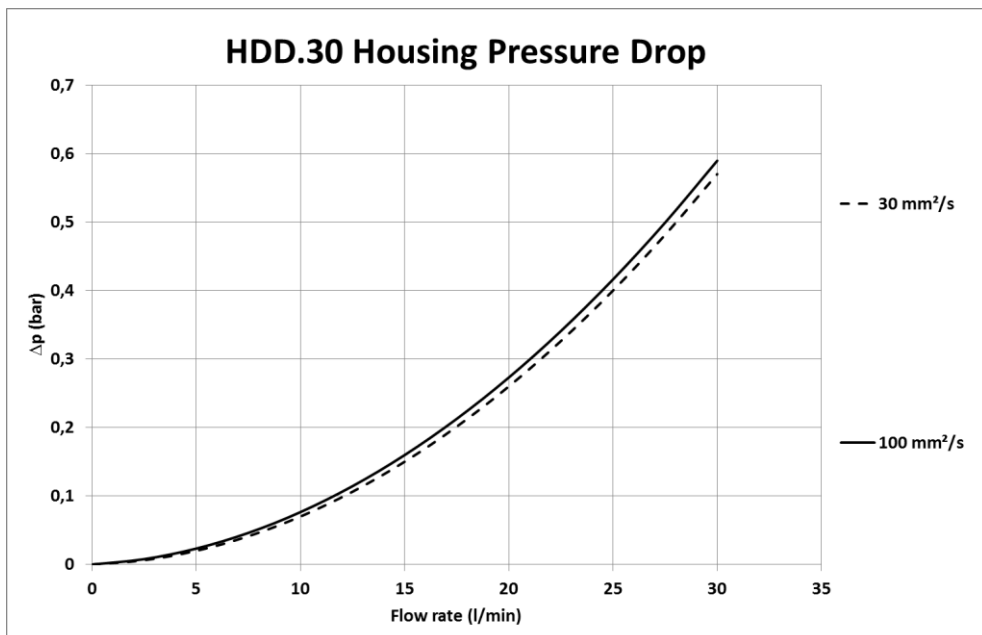

Symbols:

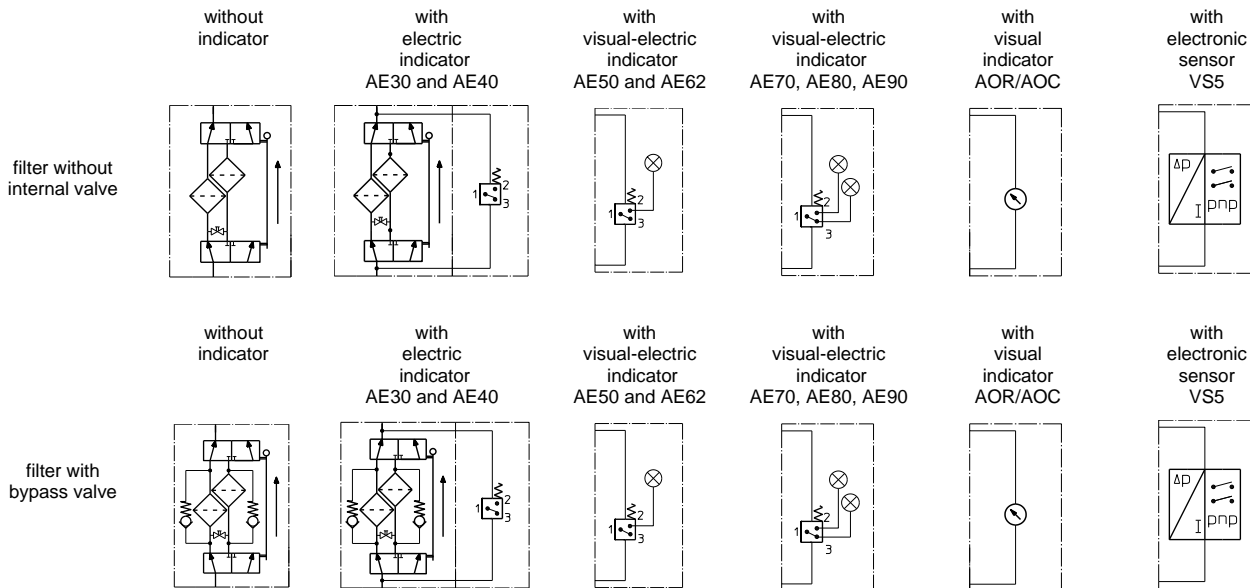

Spare parts:

item	qty.	designation	dimension	article-no.	
1	2	filter element	01E.30...		
2	2	O-ring	12,37 x 2,62	304356 (NBR)	304396 (FPM)
3	2	O-ring	40 x 3	304389 (NBR)	304391 (FPM)
4	2	support ring	48 x 2,6 x 1	305391	
5	1	O-ring	10 x 3	307285 (NBR)	311019 (FPM)
6	1	support ring	17 x 2,05 x 1	307286	
7	1	O-ring	32 x 3	304368 (NBR)	311020 (FPM)
8	4	screw plug	G ¼	305003	
9	1	clogging indicator, visual	AOR or AOC	see sheet-no. 1606	
10	1	clogging indicator, visual-electric	AE	see sheet-no. 1615	
11	1	clogging sensor, electronic	VS5	see sheet-no. 1619	
12	1	screw plug	20913-4	309817	
13	1	pressure balance valve	DN10	305000	

item 11 execution only without clogging indicator or clogging sensor

Test methods:

Filter elements are tested according to the following ISO standards:

ISO 2941	Verification of collapse/burst resistance
ISO 2942	Verification of fabrication integrity
ISO 2943	Verification of material compatibility with fluids
ISO 3723	Method for end load test
ISO 3724	Verification of flow fatigue characteristics
ISO 3968	Evaluation of pressure drop versus flow characteristics
ISO 16889	Multi-pass method for evaluating filtration performance

North America
44 Apple Street
Tinton Falls, NJ 07724
Toll Free: 800 656-3344
(North America only)
Tel: +1 732 212-4700

Greater China
No. 7, Lane 280,
Linhong Road
Changning District, 200335
Shanghai, P.R. China
Tel: +86 21 5200-0099

Europe/Africa/Middle East
Auf der Heide 2
53947 Nettersheim, Germany
Tel: +49 2486 809-0

Asia-Pacific
100G Pasir Panjang Road
#07-08 Interlocal Centre
Singapore 118523
Tel: +65 6825-1668

Friedensstraße 41
68804 Altlußheim, Germany
Tel: +49 6205 2094-0

An den Nahewiesen 24
55450 Langenlonsheim, Germany
Tel: +49 6704 204-0

EATON
Powering Business Worldwide

**For more information, please
email us at filtration@eaton.com
or visit www.eaton.com/filtration**

© 2021 Eaton. All rights reserved. All trademarks and registered trademarks are the property of their respective owners. All information and recommendations appearing in this brochure concerning the use of products described herein are based on tests believed to be reliable. However, it is the user's responsibility to determine the suitability for his own use of such products. Since the actual use by others is beyond our control, no guarantee, expressed or implied, is made by Eaton as to the effects of such use or the results to be obtained. Eaton assumes no liability arising out of the use by others of such products. Nor is the information herein to be construed as absolutely complete, since additional information may be necessary or desirable when particular or exceptional conditions or circumstances exist or because of applicable laws or government regulations.