

# Series LF 1001-1100

## DN80-125 PN32

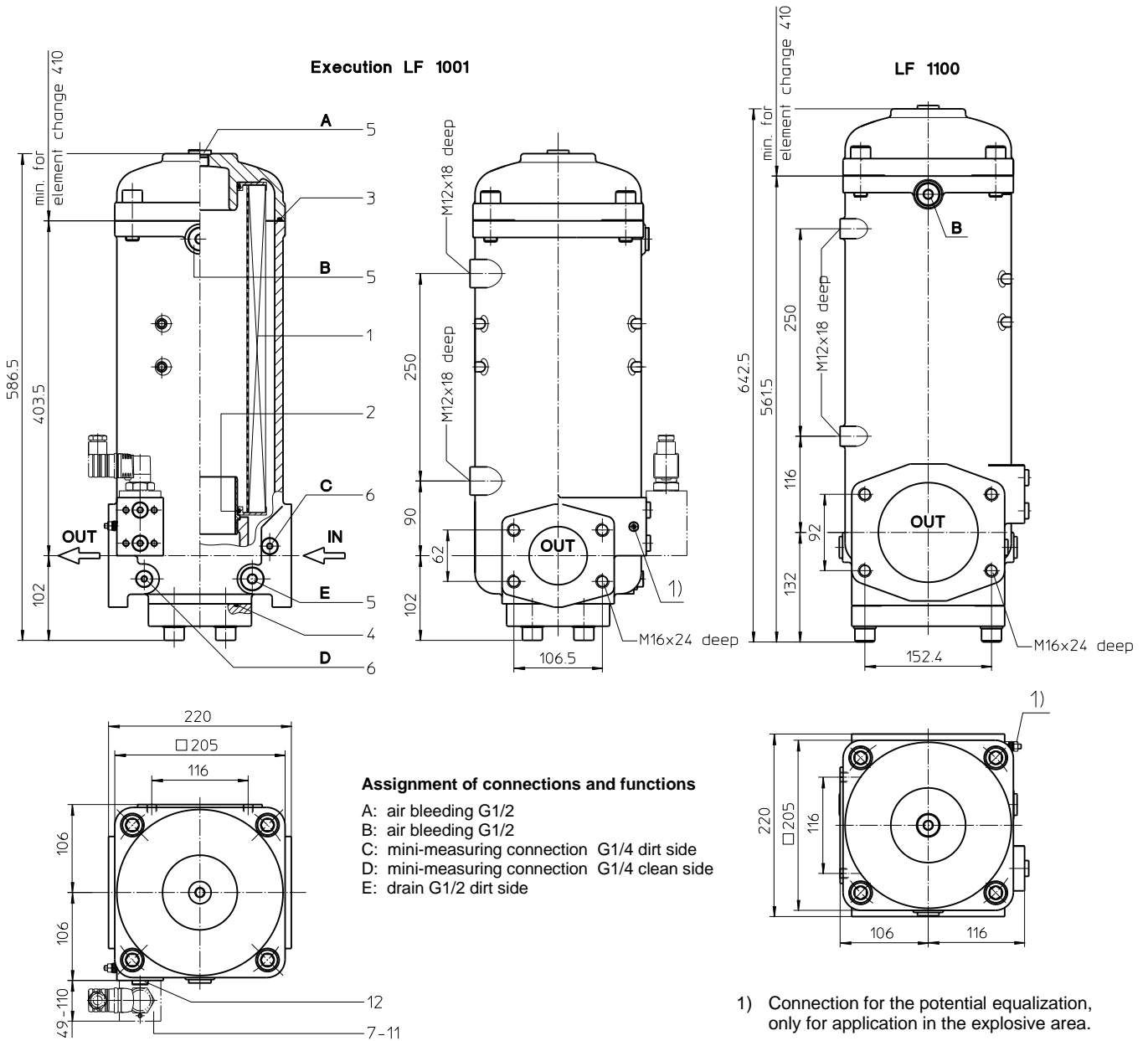

Weight LF 1001: approx. 47 kg  
 Weight LF 1100: approx. 57 kg

Dimensions: mm

Designs and performance values are subject to change.

# Pressure Filter

## Series LF 1001-1100

### DN80-125 PN32

#### Description:

In-line filters of the type LF 1001-1100 are suitable for a working pressure up to 32 bar. Pressure peaks are absorbed with a sufficient margin of safety. It can be used as suction filter, pressure filter and return-line filter.

The filter element consists of star-shaped, pleated filter material, which is supported on the inside by a perforated core tube and is bonded to the end caps with a high-quality adhesive. The flow direction is from outside to inside.

For cleaning the stainless steel mesh element (see special leaflets 21070-4 and 39448-4) or changing the filter element, remove the cover and take out the element. The mesh elements are not guaranteed to maintain 100% performance after cleaning.

For filtration finer than 40 µm, use the disposable elements made of microglass. Filter elements as fine as 5 µm(c) are available; finer filter elements are available upon request.

Eaton filter elements are known for a high intrinsic stability and an excellent filtration capability, a high dirt-retaining capacity and a long service life.

Eaton filter can be used for petroleum-based fluids, HW emulsions, water glycols, most synthetic fluids and lubrication fluids. Consult factory for specific fluid applications.

The internal valves are integrated in the filter cover. After reaching the bypass pressure setting, the bypass valve will send unfiltered partial flow around the filter.

Ship classifications available upon request.

#### Type index:

**Complete filter:** (ordering example)

<b>LF.</b>	<b>1001.</b>	<b>10VG.</b>	<b>10.</b>	<b>B.</b>	<b>P.</b>	<b>-.</b>	<b>FS.</b>	<b>A.</b>	<b>-.</b>	<b>-.</b>	<b>-.</b>	<b>AE</b>
1	2	3	4	5	6	7	8	9	10	11	12	13

- 1 series:**  
LF = in-line filter
- 2 nominal size:** 1001, 1100
- 3 filter-material:**  
130G, 80G, 40G, 25G stainless steel wire mesh  
25VG, 16VG, 10VG, 6VG, 3VG microglass  
25API, 10API microglass according to API
- 4 filter element collapse rating:**  
10 = Δp 10 bar
- 5 filter element design:**  
B = both sides open
- 6 sealing material:**  
P = Nitrile (NBR)  
V = Viton (FPM)
- 7 filter element specification:**  
- = standard  
VA = stainless steel  
IS06 = for HFC application, see sheet-no. 31601
- 8 process connection:**  
FS = SAE-flange connection 3000 PSI
- 9 process connection size:**  
A = 3" (LF 1001)  
C = 5" (LF 1100)
- 10 filter housing specification:**  
- = standard
- 11 pressure vessel specification:**  
- = standard (PED 2014/68/EU)  
IS20 = ASME VIII Div.1 with ASME equivalent material, see sheet-no. 55217 (max. operating pressure 16 bar)
- 12 internal valve:**  
- = without  
S = with bypass valve Δp 2,0 bar  
S1 = with bypass valve Δp 3,5 bar
- 13 clogging indicator or clogging sensor:**  
- = without  
AOR = visual, see sheet-no.1606  
AOC = visual, see sheet-no.1606  
AE = visual-electric, see sheet-no.1609  
OP = visual, see sheet-no.1628  
OE = visual-electric, see sheet-no.1628  
VS5 = electronic, see sheet-no.1641

To add an indicator/sensor to your filter, use the corresponding indicator data sheet to find the indicator details and add them to the filter assembly model code.

**Filter element:** (ordering example)

<b>01NR.</b>	<b>1000.</b>	<b>10VG.</b>	<b>10.</b>	<b>B.</b>	<b>P.</b>	<b>-</b>
1	2	3	4	5	6	7

- 1 series:**  
01NR = standard-return-line filter element according to DIN 24550, T4
- 2 nominal size:** 1000
- 3 - 7** see type index complete filter

#### Accessories:

- gauge port and bleeder connection, see sheet-no. 1650
- drain- and bleeder connection, see sheet-no. 1651
- SAE-counter flanges, see sheet-no. 1652

## Technical data:

operating temperature:	-10 °C to +100 °C
operating medium:	mineral oil, other media on request
max. operating pressure:	32 bar
test pressure:	64 bar
max. operating pressure with IS20:	16 bar
test pressure with IS20:	32 bar
process connection:	SAE-flange connection 3000 PSI
housing material:	EN-GJS-400-18-LT
sealing material:	Nitrile (NBR) or Viton (FPM), other materials on request
installation position:	vertical
measuring connections:	G ¼
drain- and bleeder connections:	G ½
volume tank LF 1001/1100:	11,5 l

Classified under the Pressure Equipment Directive 2014/68/EU for mineral oil (fluid group 2), Article 4, Para. 3.  
 Classified under ATEX Directive 2014/34/EU according to specific application (see questionnaire sheet-no. 34279-4).

## Pressure drop flow curves:

### Filter calculation/sizing

The pressure drop of the assembly at a given flow rate Q is the sum of the housing  $\Delta p$  and the element  $\Delta p$  and is calculated as follows:

$$\Delta p_{assembly} = \Delta p_{housing} + \Delta p_{element}$$

$$\Delta p_{housing} = (\text{see } \Delta p = f(Q) - \text{characteristics})$$

$$\Delta p_{Element} (mbar) = Q \left( \frac{l}{min} \right) \times \frac{MSK}{10} \left( \frac{mbar}{l/min} \right) \times v \left( \frac{mm^2}{s} \right) \times \frac{p}{0,876} \left( \frac{kg}{dm^3} \right)$$

For ease of calculation our Filter Selection tool is available online at  
[www.eatonpowersource.com/calculators/filtration/](http://www.eatonpowersource.com/calculators/filtration/)

### Material gradient coefficients (MSK) for filter elements

The material gradient coefficients in mbar/(l/min) apply to mineral oil (HLP) with a density of 0,876 kg/dm<sup>3</sup> and a kinematic viscosity of 30 mm<sup>2</sup>/s (139 SUS). The pressure drop changes proportionally to the change in kinematic viscosity and density.

LF	VG					G				API	
	3VG	6VG	10VG	16VG	25VG	25G	40G	80G	130G	10API	25API
1001 / 1100	0,197	0,137	0,087	0,076	0,052	0,0050	0,0046	0,0032	0,0024	0,044	0,020

### $\Delta p = f(Q)$ – characteristics according to ISO 3968

The pressure drop characteristics apply to mineral oil (HLP) with a density of 0,876 kg/dm<sup>3</sup>. The pressure drop changes proportionally to the density.

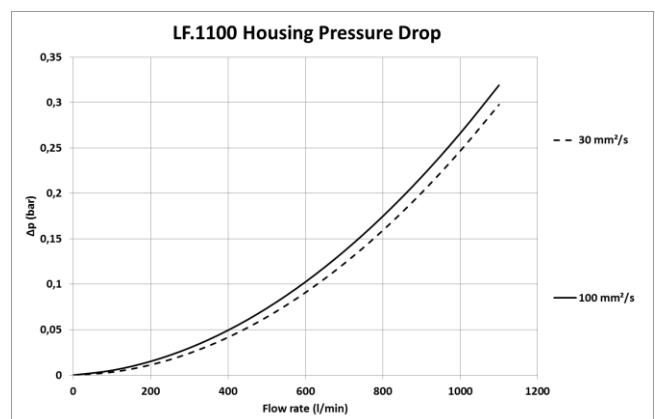
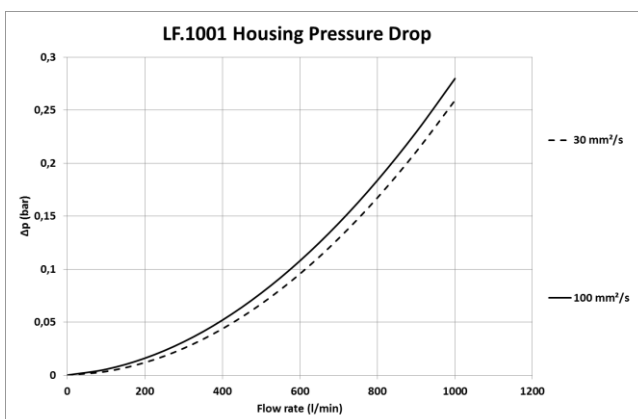

## Symbols:

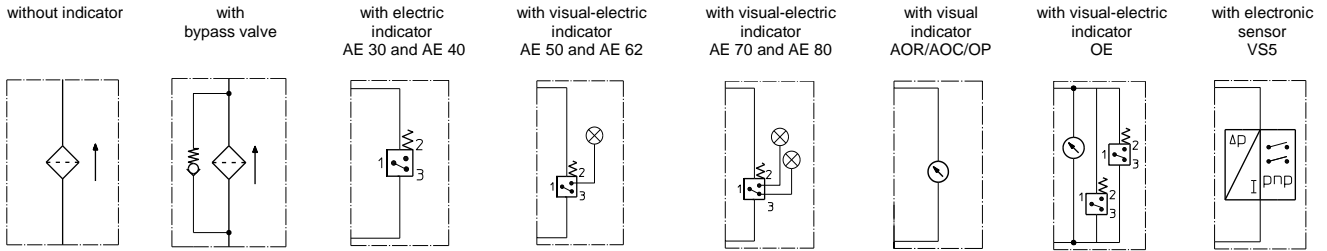

## Spare parts:

item	qty.	designation	dimension		article no.	
			LF 1001	LF 1100		
1	1	filter element	01NR.1000...			
2	2	O-ring	90 x 4		306941 (NBR)	307031 (FPM)
3	1	O-ring	185 x 4		305593 (NBR)	306309 (FPM)
4	1	O-ring (LF1001)	85,32 x 3,53		305590 (NBR)	306308 (FPM)
	1	O-ring (LF1100)	136,12 x 3,53		320162 (NBR)	320163 (FPM)
5	3	screw plug	G ½		304678	
6	2	screw plug	G ¼		305003	
7	1	clogging indicator, visual	AOR or AOC		see sheet no. 1606	
8	1	clogging indicator, visual	OP		see sheet no. 1628	
9	1	clogging indicator, visual-electric	OE		see sheet no. 1628	
10	1	clogging indicator, visual-electric	AE		see sheet no. 1609	
11	1	clogging sensor, electronic	VS 5		see sheet no. 1641	
12	2	screw plug	G ¼		305003	

item 12 execution only without clogging indicator or clogging sensor

## Test methods:

Filter elements are tested according to the following ISO standards:

ISO 2941	Verification of collapse/burst resistance
ISO 2942	Verification of fabrication integrity
ISO 2943	Verification of material compatibility with fluids
ISO 3723	Method for end load test
ISO 3724	Verification of flow fatigue characteristics
ISO 3968	Evaluation of pressure drop versus flow characteristics
ISO 16889	Multi-pass method for evaluating filtration performance

**North America**  
44 Apple Street  
Tinton Falls, NJ 07724  
Toll Free: 800 656-3344  
(North America only)  
Tel: +1 732 212-4700

**China**  
No. 3, Lane 280,  
Linhong Road  
Changning District, 200335  
Shanghai, P.R. China  
Tel: +86 21 5200-0099

**Europe/Africa/Middle East**  
Auf der Heide 2  
53947 Nettersheim, Germany  
Tel: +49 2486 809-0

**Singapore**  
100G Pasir Panjang Road #07-08  
Singapore 118523  
Tel: +65 6825-1668

Friedensstraße 41  
68804 Altlußheim, Germany  
Tel: +49 6205 2094-0

**Brazil**  
Av. Ermano Marchetti, 1435 -  
Água Branca, São Paulo - SP,  
05038-001, Brazil  
Tel: +55 11 3616-8461

An den Nahewiesen 24  
55450 Langenlonsheim, Germany  
Tel: +49 6704 204-0

**EATON**  
Powering Business Worldwide

For more information, please  
email us at [filtration@eaton.com](mailto:filtration@eaton.com)  
or visit [www.eaton.com/filtration](http://www.eaton.com/filtration)

© 2019 Eaton. All rights reserved. All trademarks and registered trademarks are the property of their respective owners. All information and recommendations appearing in this brochure concerning the use of products described herein are based on tests believed to be reliable. However, it is the user's responsibility to determine the suitability for his own use of such products. Since the actual use by others is beyond our control, no guarantee, expressed or implied, is made by Eaton as to the effects of such use or the results to be obtained. Eaton assumes no liability arising out of the use by others of such products. Nor is the information herein to be construed as absolutely complete, since additional information may be necessary or desirable when particular or exceptional conditions or circumstances exist or because of applicable laws or government regulations.